

UCL-510 — Transmitter/Multipoint Switching Combo

- ▶ 49-inch (1.25m) range. Compact sensor with 2" dead band and beam width are optimized for small tank applications
- ▶ 1" NPT mounting
- ▶ Reliable, non-contact alternative to float and conductivity level sensors for corrosive, sticky or dirty media
- ▶ Outputs continuous level and provides full pump or valve control
- ▶ PVDF transducer for corrosive liquid media

The UCL-510 is a general purpose ultrasonic sensor providing non-contact level detection up to 49.2" (1.25m), with 4 relays for switch or control functions and continuous level measurement. This compact unit offers a non-contact alternative to our float or conductance sensors in small tank chemical feed or handling applications when corrosive, sticky or dirty media is involved.

The configuration software, supplied with the sensor, provides flexible system integration or retrofit of existing level devices with configuration control. Integral level automation functions can further reduce system costs through the reduction of external control hardware. The analog output enables local tank level indication, remote PLC monitoring or automation functions. Gems UCL-510 is the non-contact solution for small tank level switch, control and measurement.

Specifications

Range	49.2" (1.25 m)
Accuracy	0.125" (3 mm)
Resolution	0.019" (0.5 mm)
Beam Width	2" (5 cm)
Dead Band	2" (5 cm)
Supply Voltage	24VDC (loop)
Loop Resistance	400Ω max.
Consumption	0.5W
Signal Output	4-20 mA, two-wire (when loop powered)
Contact Type	(4) SPST relays 1A
Loop Fail-Safety	4 mA, 20 mA, 21 mA, 22 mA or hold last
Relay Fail-Safety	Power loss: Hold last; Power on: Open, close or hold last
Hysteresis	Selectable
Configuration Software	PC Windows® USB 2.0
Temp. Comp.	Automatic over range
Process Temp.	20°F to 140°F (-7°C to +60°C)
Ambient Temp.	-31°F to +140°F (-35°C to +60°C)
Pressure	MWP = 30 PSI
Enclosure	Type 6P encapsulated, corrosion resistant & submersible
Encl. Material	PC/ABS FR
Strain Relief Mat.	Santoprene®
Trans. Material	PVDF
Cable Length	48" (1.2 m)
Cable Jacket Mat.	Polyurethane
Process Mount	1" NPT (1" G)
Mount. Gasket	Viton®
Classification	General Purpose
Approvals	CE, cFMus



Typical Applications

- Water and Waste Water
- Control Automation
- Chemical Feed
- Food and Beverage
- Acids, Inks, Paints
- Slurries

Control and Switch Functions

- 2 pumps with 2 alarms
- 1 pump with 3 alarms
- 2 pumps (lead-lag) with 2 alarms
- 2 pumps (duplexing) with 2 alarms
- 4 level switch points

Versatile Application

Controller

- Auto fill/empty
- Can control 2 pumps/valves
- Lead/lag
- Duplex
- Unused relays may be used as additional alarms

The UCL-510 feature programmable level intelligence and can be reconfigured for different sensing duties (such as switch actuation points) after installation. This is an advantage over our float or conductivity type sensors. The user-friendly configuration software provides un-matched accuracy and programming for control applications. Multi-function relay control, coupled with 4-20 mA output generates amazing control capabilities. Advanced signal processing techniques provides the UCL-510 with next generation digital processing for control. The UCL-510 is level control made simple.

Switching

- High level alarm (1-4)
- Low level alarm (1-4)
- Any combination of high and/or low alarms

The UCL-510 provides a non-contact alternative to our float and conductivity probes multipoint level switches. It combines 4 built in SPST relays, with a selectable hysteresis that eliminates relay chatter from turbulent media. Additionally, non-contact sensors are immune to the performance issues influenced by changes in a media's specific gravity.

Continuous Transmitter

- Adjustable 4-20 mA output
- Reversible output
- Interface directly to local display and/or to PLC, SCADA, DCS systems
- Remote displays/controllers can increase relay functionality

The UCL-510 is a good non-contact alternative to our XT float type transmitters for challenging media that can damage moving parts. The UCL-510 is for sticky, scaling or corrosive media. It provides exceptional measurement accuracy (0.125"), resolution (0.019") and repeatability ensuring overall system performance reliability.

Wiring

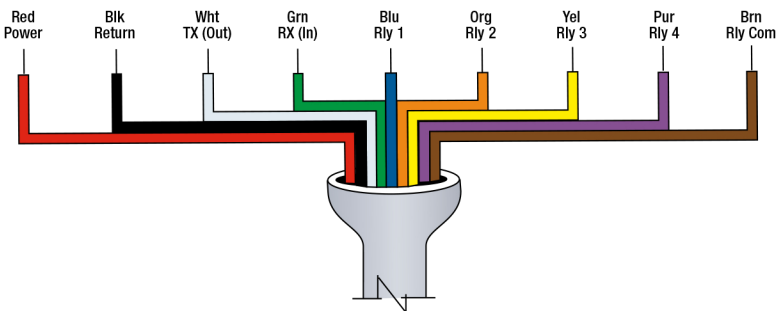

How To Order

Select by Part Number.

Description	Part Number
UCL-510 Transmitter/Multipoint Switch with Configuration Software and Fob	225100
Replacement/Additional Configuration Fob	227100

Configuration Software

- Free download @ GemsSensors.com/software
- Windows XP or 2000 compatible; USB 2.0 connection
- Provides configuration, file management (saving, printing, backup), and troubleshooting

The user interface allows you to take complete visual control of your set-up and configuration. Using simple menus and visual representations, the confusion of target calibration are gone. Once you have completed your configuration design, simply click "Write to Unit" and the UCL-510 is configured. It also enables multiple UCL-510's to be configured with just a click of the button. It even generates viewable and printable PDF wiring diagrams of your configurations to simplify and ensure proper field installation.

Gems supplies the USB Fob required to use the configuration software with each UCL-510 sensor. Replacements or additional Fobs may be ordered separately.

Dimensions

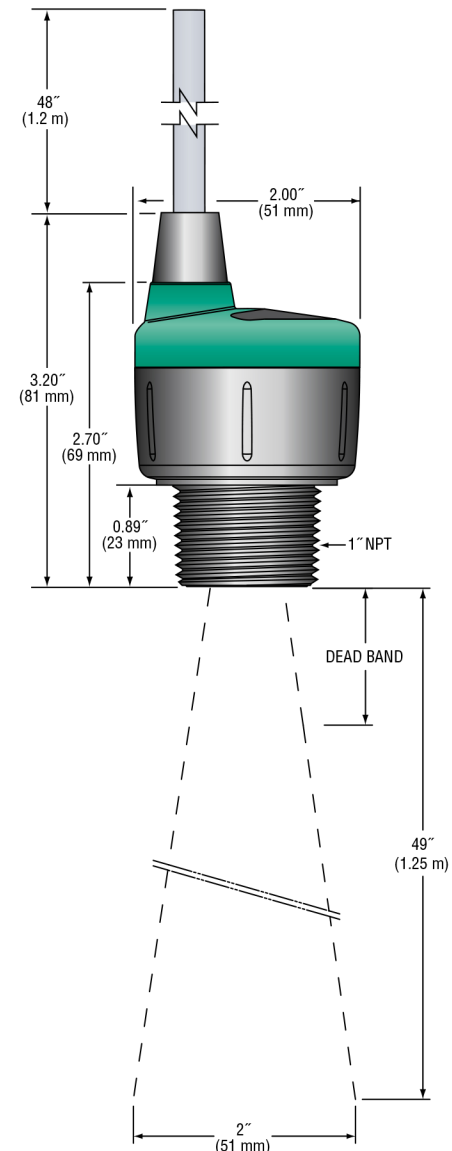

LEVEL SENSORS - CONTINUOUS